

KS32C5000(A) interface

Title		
ARM7S BOARD		
Size	Document Number	Rev
B	1	0.0
Date:	Friday, April 09, 1999	Sheet 1 of 1

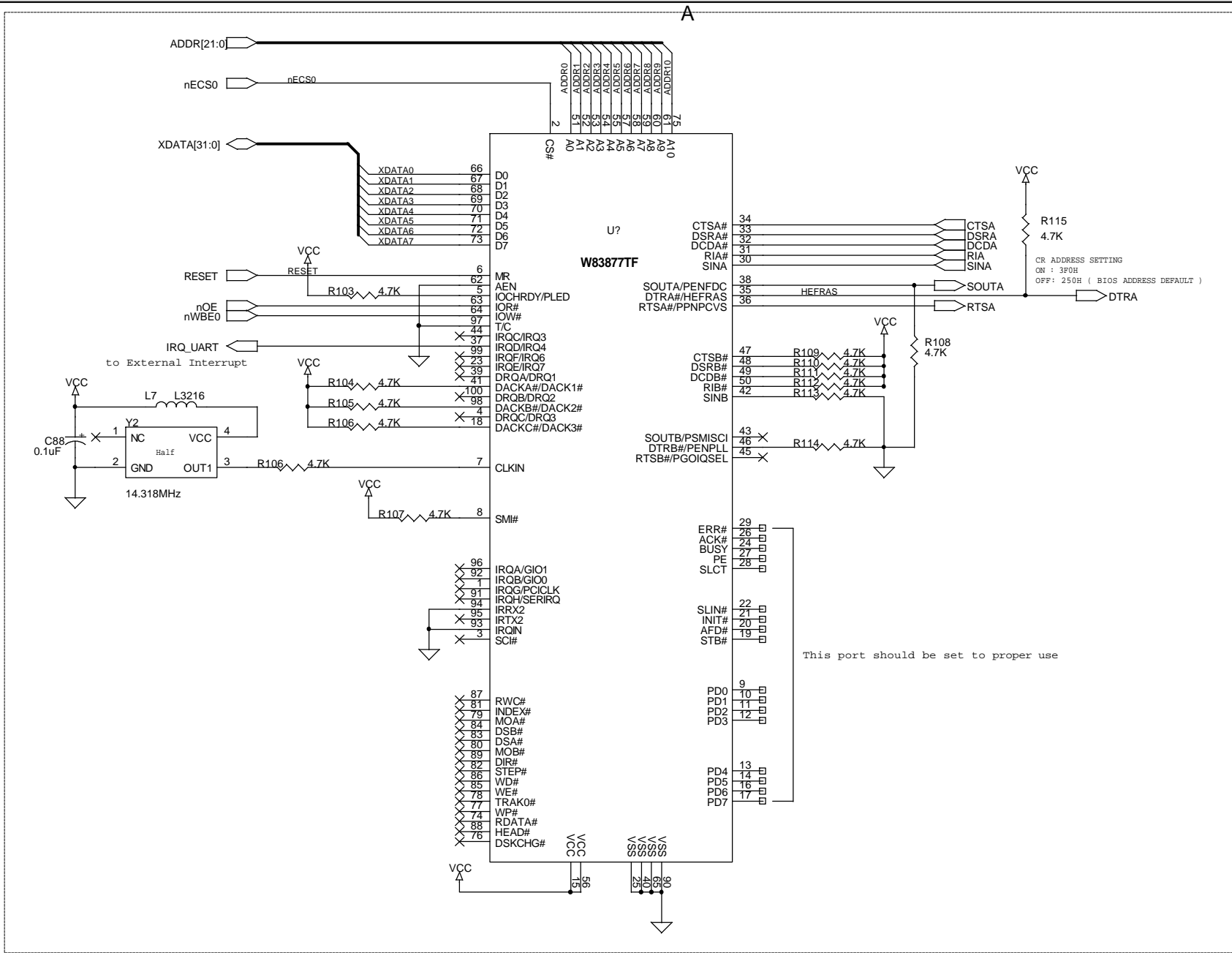

CR ADDRESS SETTING  
ON : 3F0H  
OFF: 250H ( BIOS ADDRESS DEFAULT )

This port should be set to proper use

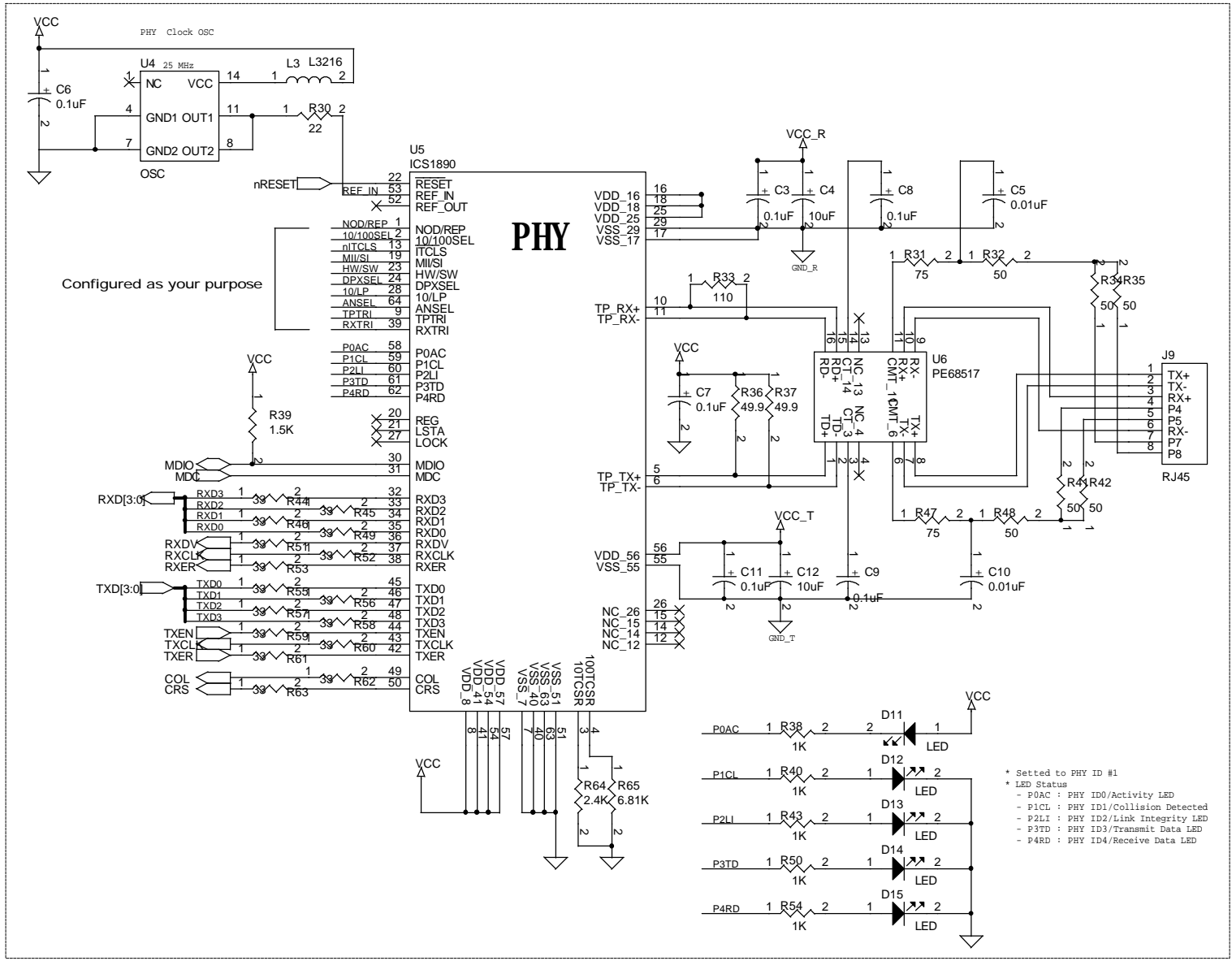

Title		
ARM7S BOARD		
Size	Document Number	Rev
B	1	0.0
Date:	Friday, April 09, 1999	Sheet 1 of 1

A

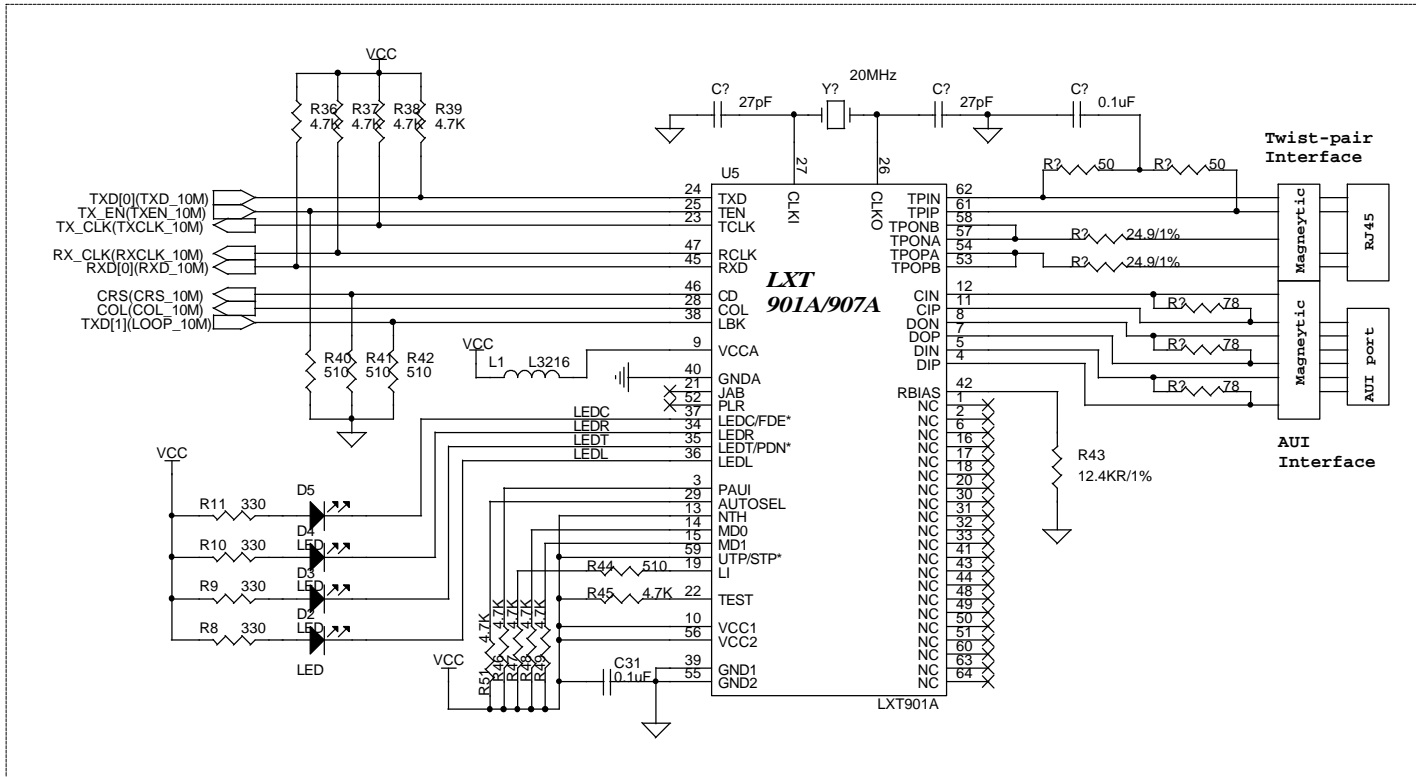

A

Title		
ARM7S BOARD		
Size	Document Number	Rev
B	1	0.0
Date:	Saturday, April 10, 1999	Sheet 1 of 1

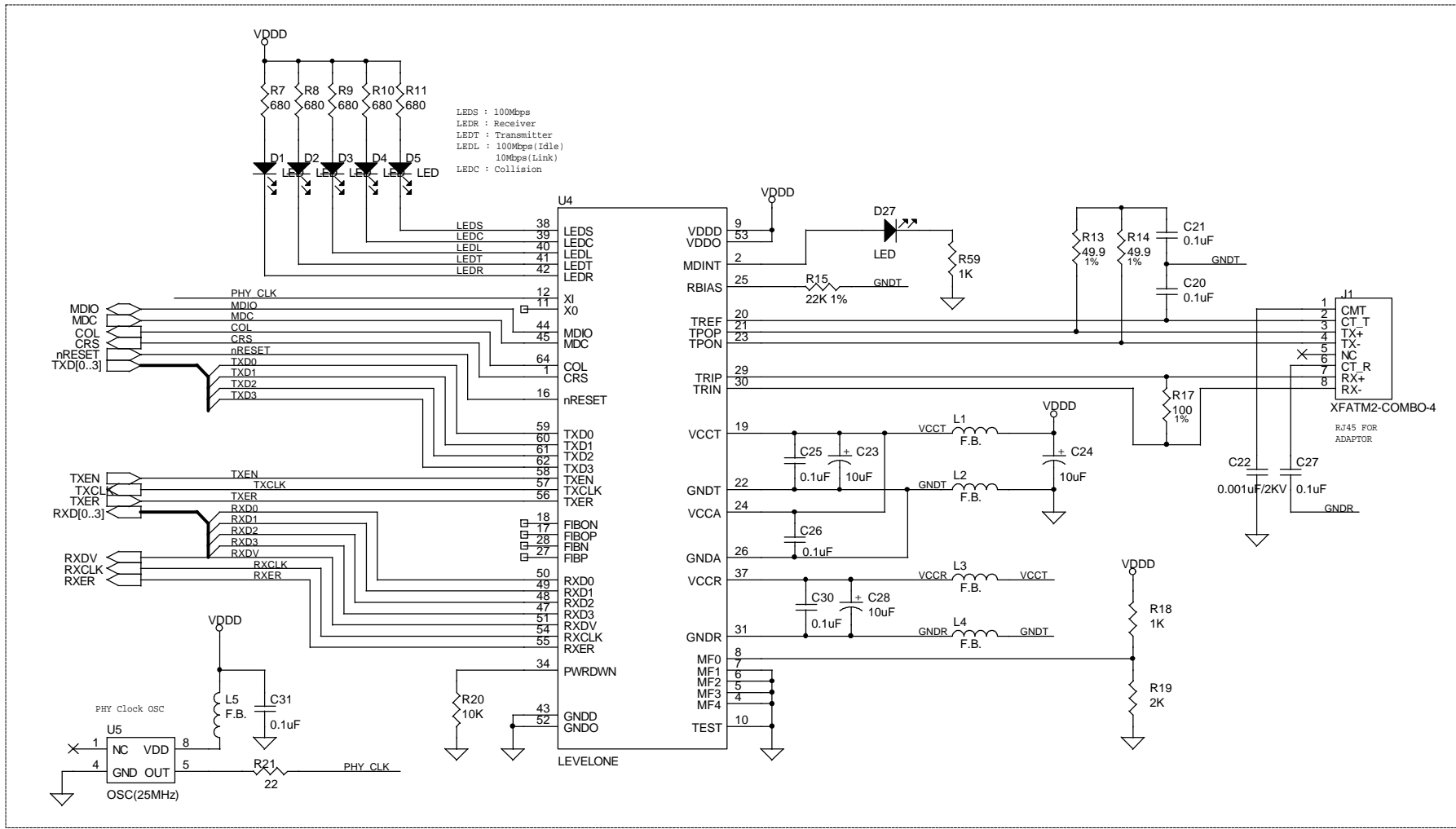

Title		
ARM7S BOARD		
Size	Document Number	Rev
B	1	0.0
Date:	Friday, April 09, 1999	Sheet 1 of 1

A

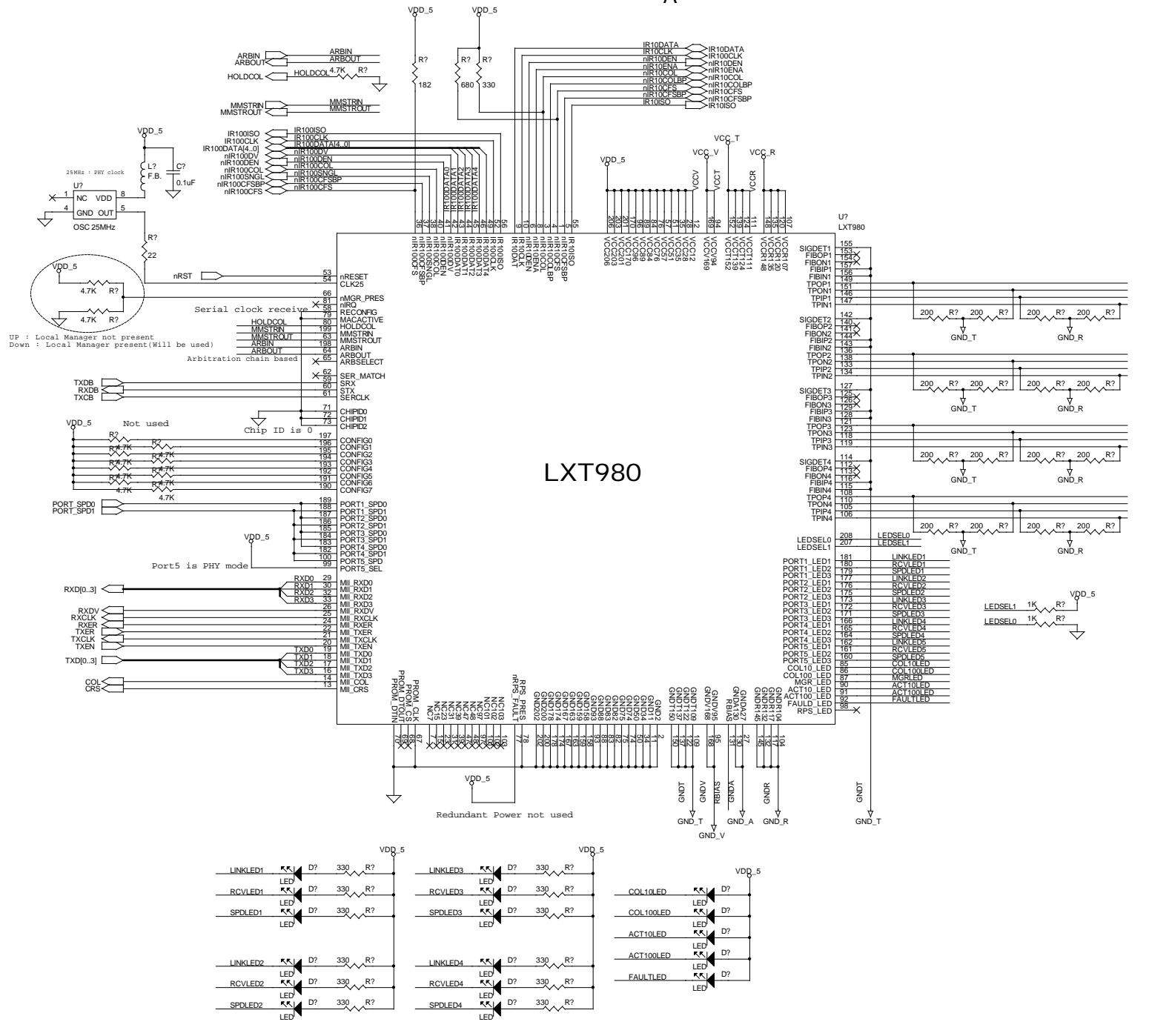

A

A

A